

Warranty Information

Proof of purchase will be required.

The guarantee does not cover faults or damage caused by incorrect installation and/or maintenance, ordinary wear and tear, water composition, etc.

*Please see www.deva-uk.com for full terms and conditions of warranty

Cleaning

Your product has a high-quality finish and should be treated with care to preserve the visible surfaces. Never use abrasives or abrasive cleaning agents to clean this product clean regularly with contamination free warm water and a damp soft cloth. Do not use products containing chlorine bleach or hydrochloric acid as these can damage the product.

We have a policy of continuous improvement and reserve the right to change specifications without notice.

METHVEN UK LIMITED
METHVEN EXPERIENCE CENTRE
3/3A STONE CROSS COURT
YEW TREE WAY
GOLBORNE
WARRINGTON
WA3 3JD
UNITED KINGDOM

INST-ADORE313
26.04.2023

TEL: 0800 195 1602
FAX: 0844 406 8690
EMAIL: sales@uk.methven.com
www.deva-uk.com
www.methven.com

ADORE MINI BASIN MIXER

ADORE313 Installation Guide

Technical Specification

Operating Pressure

Min: 0.1 Bar

Max: 5.0 Bar

Operating Temperature

Hot: 65°C

Cold: 5°C

Inlet Connections

1/2" BSP



Please read all of the instructions before installation.

General

Methven recommends this product is installed by a competent person in compliance with all relevant regional regulations.

After installation all connections must be checked for leaks.

All outlets used primarily for personal hygiene shall deliver water at a safe temperature as per regional regulations.

It is the responsibility of the installer to ensure a waterproof seal is achieved.

Tap Installation Instructions

- 1) Fit the rubber O-ring washer into the recess in the bottom of the mixer tap.
- 2) Insert the fixing bolts into the bottom of the tap, with the slot facing out and using a flat bladed screwdriver tighten these up.
- 3) Screw the flexible tails into the bottom of the tap, by hand, until tight. Do not use PTFE tape, or similar, on the threads.
- 4) Feed the tails and fixing bolt into the hole in the basin, ensuring that rubber washer is seated correctly and fully covering the hole.
- 5) From the underside of the basin feed the rubber horseshoe shaped washer over the fixing bolts followed by the metal one. Place the nuts over the fixing bolts and tighten until the tap is fixed on the basin. Do not overtighten.
- 6) Connect the hot and cold feeds to the water supply.
- 7) Reinststate the water supply and test for leaks.

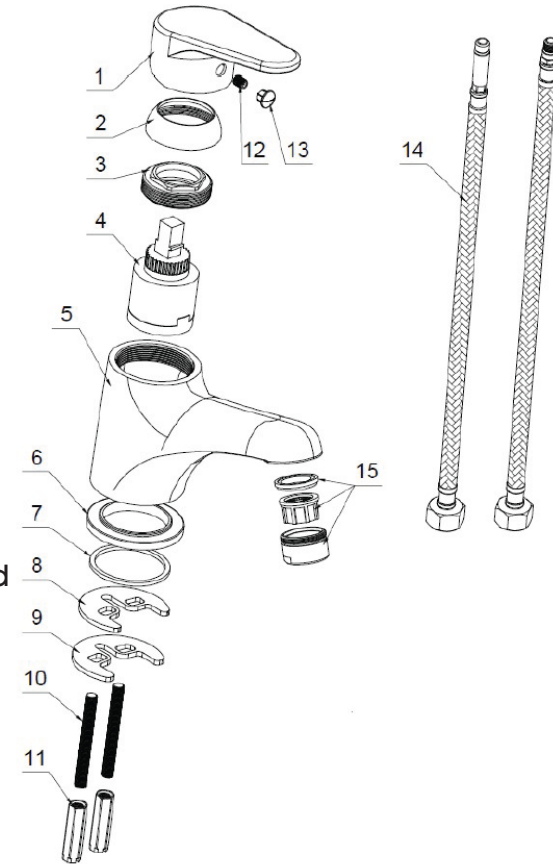

Do not stretch or twist hose

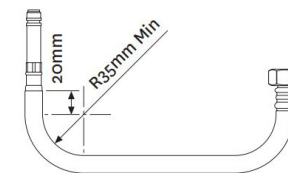
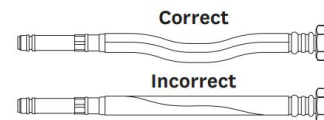

**DO NOT crush
Hose or swaged
Ends**